

ASPEN HILLS SUBDIVISION - CURVE TABLE

NO	RADIUS	DELTA	ARC LGT	TAN
1	165.00	50°09'24"	144.44	77.22
2	120.00	91°48'29"	192.28	123.85
3	575.00	45°49'07"	491.81	259.91
4	275.00	22°57'49"	110.22	55.86
5	135.00	35°10'35"	82.88	42.79
6	315.00	73°12'04"	402.44	233.94
7	410.00	5°20'17"	38.20	19.11
8	195.00	33°10'06"	112.89	58.07
9	105.00	47°14'58"	86.59	45.93
10	105.00	24°42'38"	45.28	23.00
11	165.00	19°35'36"	56.42	28.49
12	165.00	35°36'50"	102.56	53.00
13	70.00	91°48'29"	112.17	72.24
14	615.00	10°56'05"	117.37	58.86
15	615.00	9°46'31"	104.93	52.59
16	615.00	9°38'09"	103.43	51.84
17	615.00	10°16'41"	110.32	55.31
18	615.00	1°34'38"	16.93	8.47
19	135.00	26°56'52"	63.49	32.35
20	135.00	8°13'43"	19.39	9.71
21	315.00	5°55'40"	32.59	16.31
22	315.00	38°57'30"	214.19	111.42
23	315.00	28°18'54"	155.70	79.46

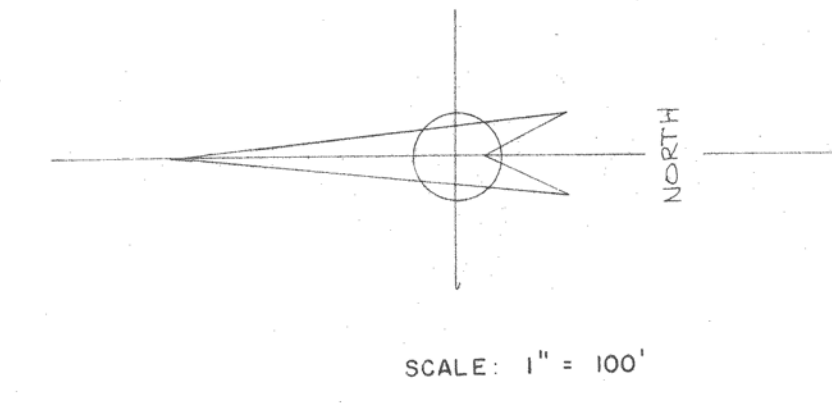

NOTE: ALL UTILITY EASEMENTS ARE 15' WIDE AND ARE LOCATED 7.5' ON EACH SIDE OF LOT LINES NOT ADJACENT TO ROADS.

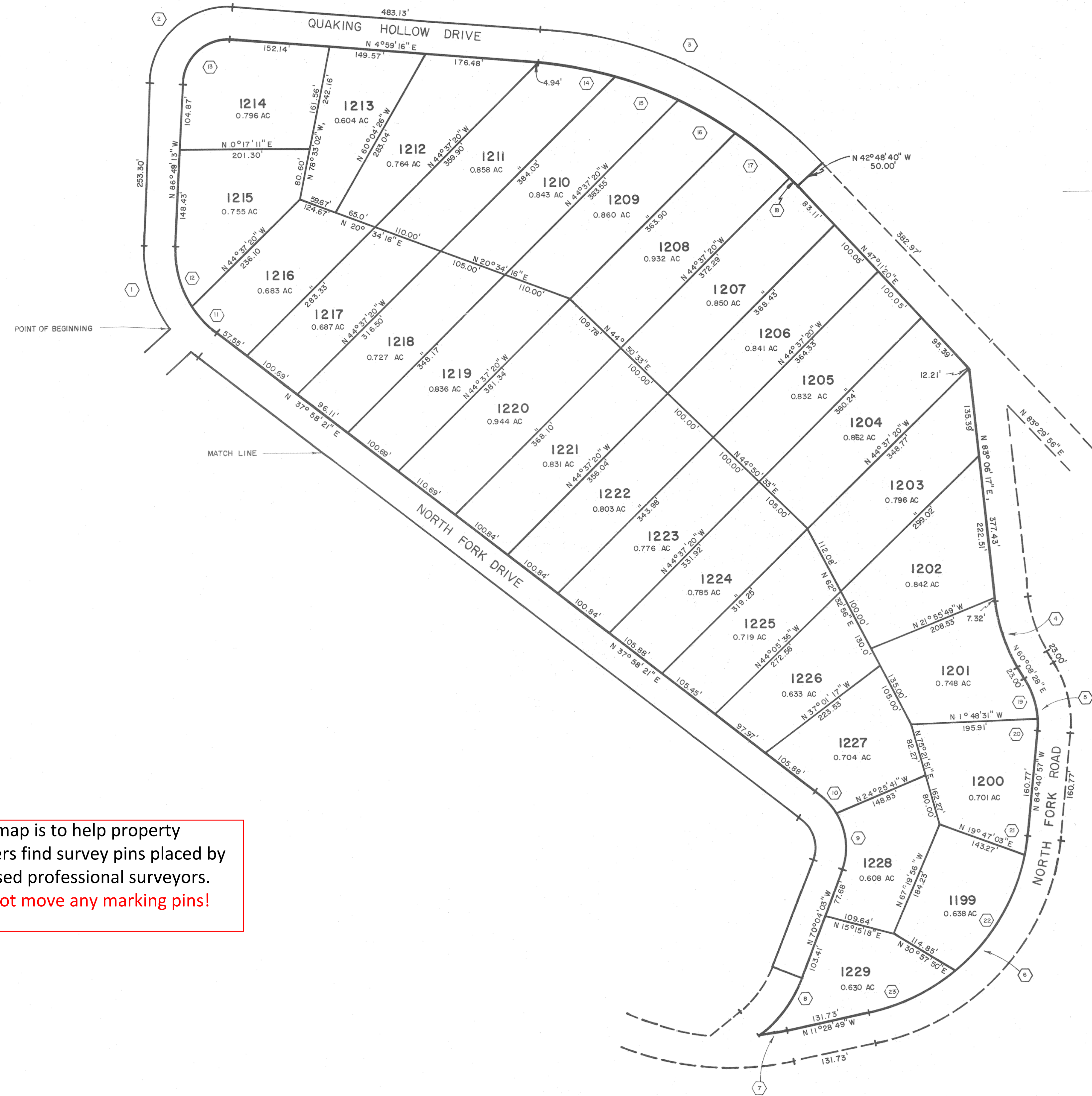

This map is to help property owners find survey pins placed by licensed professional surveyors.
Do not move any marking pins!

Plat "E"